

Damping Electromechanical Oscillations using remote signal fed STATCOM

J. G. Ambafi¹ and S. S. Adamu²

¹ambafi@futminna.edu.ng, ²ssadamu.elle@buk.edu.ng

¹Department of Electrical and Electronics Engineering, Federal University of Technology, Minna.

²Department of Electrical Engineering, Bayero University, Kano.

Abstract: This paper investigates the effects of Static Synchronous Compensator (STATCOM) on electromechanical oscillations damping in a wide area network of power system. It focuses on the use of STATCOM and Phasor Measurement Units (PMU) to damp generators speed deviations and bus voltage profile improvement. The network performances were evaluated without remote centre called Power Oscillation Damper (PDC) serving as input to STATCOM in enhancing the system stability. The case study was mathematically modelled using system parameters in Power System Analysis Toolbox (PSAT) environment where most of the simulations were carried out. Finally, the overall performance of the network was evaluated by nonlinear simulations, and results obtained showed the effectiveness of the use of remote inputs in improving the dynamic stability of the system and provided better damping to the power swings.

1. INTRODUCTION

Small-signal stability deals with power system stability analysis when subjected to small disturbances. If power system oscillations caused by small disturbances can be suppressed, such that the deviations of system state variables remain small for a long time, the power system is stable. On the contrary, if the magnitude of oscillations continues to increase or sustain indefinitely, the power system is unstable (Wang, *et al*, 2008). Since, one of the principal tasks in power system analysis is to carry out small-signal stability analysis to assess the power system under the specified operating conditions (Wang, *et al*, 2008), this paper examines small signal stability in a wide area network having all the generators behaviour linked to the remote centre serving as an input to the controller (STATCOM) for oscillation damping.

The problem of electromechanical oscillation damping has been previously approached using local input signals as reported in (Mithulananthan, *et al* 2002; Robak, *et al* 2003, Kanojia and Chandrakar, 2009, Reddy, *et al*, 2010, Magaji, *et al* 2012, James, *et al*, (2012), Ghosh & Senroy, 2012, Safari, *et al* 2013 and Amin, 2013). The use of wide area measurements (WAMS) to set remote base signals that forms a close loop in order to control and damp electromechanical oscillations were reported in (Swain, *et al* 2015, Srikanta, *et al* 2014, Weiss *et al.*, 2016).

The development of synchronized phasor measurements, fibre optic communications, digital controllers, and other IT advances have spurred development of wide-area controls. Wide-area controls

offer increased observability and controllability of systems it covers. They may augment local controls, or provide supervisory or adaptive functions rather than primary control. In particular, voltage, speed deviation, active and reactive power, phase angles related to generator rotor angles, are often advocated as input signals (Ray *et al*, 2008). The synchronized phasor measurement is achieved through the synchrophasor, also known as the Phasor Measurement Unit (PMU). The PMU is a device enabling the precise measurement of electric waves on a grid. It is used for high voltage measurements and came to be regarded as one of the most important instruments in the given context. PMU's main function consists in monitoring the grid "health", improving the stability and robustness, connecting island networks, and interconnecting two different networks. The measurements from different PMUs are combined together and provide a comprehensive overview of the entire interconnection and grid stress; alternatively, they are used to trigger corrective actions to maintain stability, (Aweya & Al Sindi, 2013, Brunner & Antonova, 2011 and Carta *et al*, 2008).

With improved applications of synchronized PMU technology, wide area measurements (WAMS) technology is being applied in power system, which is also one obvious technical feature of the coming smart grid (Bose, 2010a, b, De La Rue *et al*, 2010 and Chakraborty *et al*, 2011). Therefore, it would be wonderful to construct WAMS-based FACTS supplementary wide-area damping control strategy, that combines the quick and flexible control abilities of FACTS devices and the global monitoring ability of

WAMS, to prevent the low-frequency oscillation (especially the inter-area oscillation) and enhance the global stability of the power system.

This research work investigates the effect of STATCOM fed by remote signal to damp electromechanical oscillations. The methodology is tested using Kundur 4 machine system

2. METHODOLOGY

The approaches adopted are similar to some other previous work, but with slight modifications:

- i. A single test system is taken into consideration as a benchmark system.
- ii. Details of placement of PDC as well as STATCOM were carried out based on optimization.
- iii. The selection of appropriate stabilizing signal is detailed based on oscillatory mode of all the generators.

The proposed methods shall be tested on Kundur 4machine 11 bus system. The effectiveness of the proposed methods shall be demonstrated through eigenstructure analysis and time-domain simulation in MATLAB software.

Brief Overview of Kundur four machine 11 bus System

The network as shown in Figure 1 has four generators and generator of the test systems is equipped with the AVR Type III, which is the simplest AVR model that can be used for rough stability evaluations. Each generator is described by six order nonlinear mathematical model while excitors by third order. The sixth order model of generator is obtained assuming the presence of a field circuit and an additional circuit along the d-axis and two additional circuits along the q-axis (Milano, 2007). PMUs are placed at the output of each generator serving as the observable points.

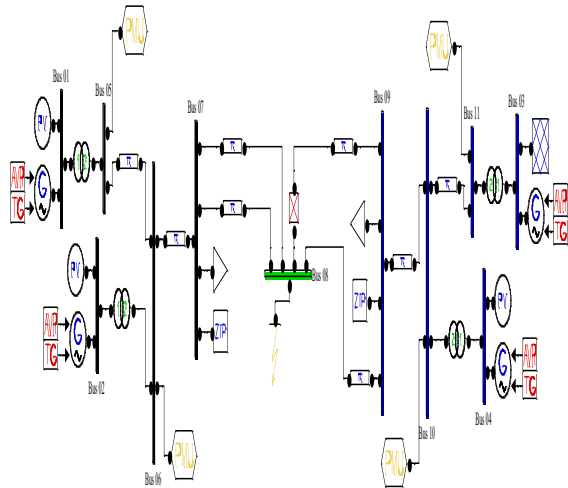

Figure 1: Kundur four machine 11 bus two area power system.

Power Systems model

The dynamics of power system in linearized form is represented as

$$\begin{aligned} \dot{x} &= Ax + Bu \\ y &= Cx + Du \end{aligned} \quad (1)$$

A, B, C are state, input, and output matrices respectively. D directly connects input (u) with output (y).

Eigenvalue analysis

The stability of operating point may be analysed by studying the eigenvalues. The operating point is stable if all of the eigenvalues are on the left-hand side of the imaginary axis of the complex plane, otherwise it is unstable. If any of the eigenvalues appear on or to the right of this axis, the corresponding modes are said to be unstable, as is the system. The eigenvalues λ are calculated for the state matrix A , which are the non-trivial solutions of the equation (Graham, 2000)

$$A\Phi = \lambda\lambda \quad (2)$$

where, Φ is the right eigenvector of the state matrix A and is n by 1 vector. Quite similarly, the n -row vector Ψ which satisfies

$$\Psi A = \lambda\Psi \quad (3)$$

is called the left eigenvector associated with the eigenvalue λ . Rearranging (3) to solve for λ yields the characteristic equation of matrix A given as

$$\det(A - \lambda I) = 0 \quad (4)$$

and the values of λ which satisfy the characteristic equation are the eigenvalues of state matrix A . These eigenvalues may be real or complex, and are of the form, $\lambda = \sigma \pm j\omega$. The real part of the eigenvalue gives the damping while the imaginary part computes the frequency of oscillation. If the real eigenvalue is negative, the mode decays over the time. The larger the magnitude of the mode, the quicker it decays. But, on the other hand, if the real eigenvalue is positive, the mode is said to have a periodic instability (Snyder, 1997).

If state matrix A is real, the complex eigenvalues always occur in conjugate pairs. The conjugate pair complex eigenvalues ($\sigma \pm j\omega$) correspond to an oscillatory mode. A pair with a positive σ represents an unstable oscillatory mode since these eigenvalues yield an unstable time response of the system. In contrast, a pair with a negative σ represents a desired stable oscillatory mode. Eigenvalues associated with an unstable or poorly damped oscillatory mode are called dominant modes since their contribution dominates the time response of the system.

The electromechanical modes are obtained from some complex eigenvalues of A

$$\lambda_i = \sigma_i \pm j\omega_i \quad (5)$$

The damped frequency of the oscillation in Hertz is given by:

$$f_i = \frac{\omega_i}{2\pi} \quad (6)$$

represent frequency in Hz and damping ratio of the i th mode, respectively.

and the damping factor (or damping ratio) is given by

$$\zeta_i = \frac{-\sigma_i}{\sqrt{\sigma_i^2 + \omega_i^2}} \quad (7)$$

The oscillatory modes having damping ratio less than 3% are said to be critical. 5% represent sufficient but not good enough. However, a power system is considered to be well damped if the damping for all eigenvalues is greater than 15%.

The transfer function representation (1) between j th input and k th output is written as

$$G(s) = \sum_{i=1}^{i=n} \frac{R_i}{s - \lambda_i} \quad (8)$$

where: $R_i = C_k \varphi_i \psi_i B_j$ is modal residue corresponding to λ_i . Symbols φ_i and ψ_i are right and left eigenvectors corresponding to λ_i , respectively.

Approach of Signal Selection

The criteria for chosen the feedback signal includes:

- The best signal-actuator combination should have the highest residue for all operating conditions.
- In order to have a uniform damping contribution, the variation in $|R_i|$ and $\angle R_i$ should be minimum.

The proposed remote centre assumes that feedback signals are readily available to the controller without delay, resistance and capacitance. However, in practical scenario, each signal will be associated with its own time delay, resistance and capacitance. Various controller design methodologies proposed in Yao, et al (2014) could be used to tackle the problem caused by the time delay uncertainties. Since the objective of this paper is to demonstrate the effect of remote based STATCOM for electromechanical oscillations damping using eigenstructures as methodology, the simple eigenstructures method is used in this paper.

Feedback Signal for STATCOM

Two feedback signal to improve the damping of each interarea mode were considered. They are speed deviation of the four synchronous generators and their voltages were used. All signal allocations are considered here for demonstration purpose.

Optimal location of PDC and STATCOM using Genetic Algorithm

The objective function is based on voltage deviation so as to maintain the voltage at all buses within an acceptable limit (0.95-1.10).

Bus voltage is one of the most important determinant of securities and quality service, one of the effective ways to avoid the voltages from moving toward maximum or minimum limits after optimization, is to minimise the deviation of voltage from the desired value as an objective function, that is

$$\min f_2 = \sum_{i=1}^{H_L} \frac{|v_i - v_i^*|}{H_L} \quad (9)$$

Where f_2 is the per unit average voltage deviation, H_L is the total number of the system load buses, v_i and v_i^* are the actual voltage magnitude and the desired voltage magnitude at bus i .

where: $0.95 \leq V_i \leq 1.10$

Generation = 11, Crossover = 25% and Mutation = 1%

3. RESULTS

Decision making on the final supplementary input signal was carried out based on both pre-fault and post-fault conditions. The proposed procedures were tested on Kundur 4machine 11 bus system. The effectiveness of the proposed methods has been demonstrated through the time-domain simulation in PSAT as modelled in MATLAB software. Table 1 present the optimization result obtained using genetic algorithm (GA).

Table 1: Optimization on voltage deviation

Bus	VD	% Deviation
1	0.03	3
2	0.01	1
3	0.03	3
4	0.01	1
5	0.0035	0.35
6	0.0274	2.74
7	0.0468	4.68
8	0.0699	6.99
9	0.033	3.3
10	0.0202	2.02
11	0.006	0.6

The optimization result shown in Table 1 shows that the best bus for the placement of PDC connecting the remote signals and STATCOM is the bus with the highest percentage of voltage deviation which is bus 8.

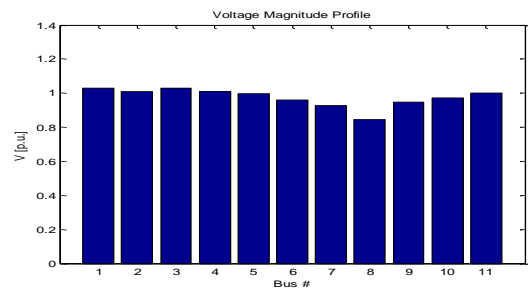

Figure 2: Voltage profile of the case study network without PDC and STATCOM

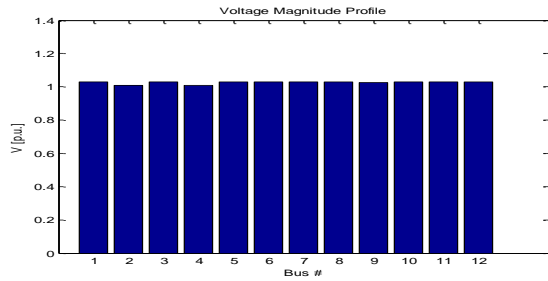

Figure 3: Voltage profile of the case study network modified with PDC and STATCOM

Figure 2 presents the voltage profile of the network which shows some unacceptable voltage level outside $\pm 10\%$ away from 1. With the introduction of STATCOM and remote signal as input to the controller Figure 3 shows a remarkable improvement in the voltage profile of the network.

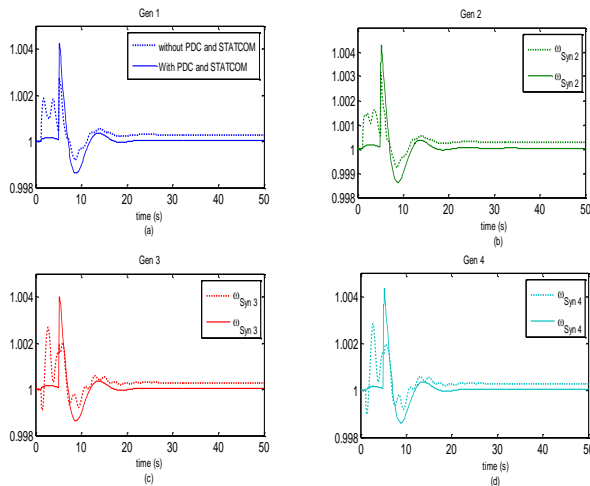

Figure 4: Speed deviation of the case study network modified with and without PDC and STATCOM

The speed deviation of each synchronous generator with and without remote centre is shown in Figure 4 showing pre-fault and post-fault responses. The broken lines represent the network without remote centre and STATCOM and the continuous lines represent the network with both remote centre and STATCOM.

Table 2: Eigenvalue analysis of the case study network without PDC and STATCOM

Modes shape	Mode	Frequency	Damping ratio	
2 and 4	-0.879 $\pm j6.281$	1.009	0.139	13.853
1 and 3	-0.234 $\pm j3.506$	0.559	0.067	6.656

Table 3: Eigenvalue analysis of the case study network with PDC and STATCOM

Modes shape	Mode	Frequency	Damping ratio	
1	-0.794 $\pm j7.924$	1.268	0.100	10.000
3	-1.125 $\pm j8.028$	1.29	0.139	13.900

4	-0.678 $\pm j7.958$	1.271	0.085	8.500
---	------------------------	-------	-------	-------

Tables 2 depict worse cases and shows the mode shapes, modes, frequency and the damping ratio of the synchronous generators. On table 2 the interaction between generator 1 and 3 made the oscillatory mode not to be too good. Table 3 shows the influence of both the remote signals and STATCOM in making the machines to revolve around the same percentage of damping.

Discussion of Results

Notably, the investigation carried out in this study helped to further establish the flexibilities associated with remote base signals. This could bring about robust controller design that could be effective in oscillation damping. In order to validate the investigation and performance of the idea, time domain simulation studies were performed on the system. A balanced, short circuit fault was applied at bus 8 at time $t= 5s$ and lasted for 0.1s. The fault is cleared at the end of almost two cycles. Figure 4 shows the speed deviation in the system with and without using damping controllers. The results are obtained for nominal operating conditions. It is evident from the figures that the controllers offer improved damping for the system oscillatory modes. The PMUs were placed on the generator buses so as to see them observable from the remote centre.

4. CONCLUSION

This paper presents an investigation on the damping of electromechanical oscillations through remote control using STATCOM on the case study. The STATCOM was optimally located using GA. Simulations were carried out in which case: the voltage profile was improved; the of speed deviations improved and the interarea modes were shaped hence, stability improved. The eigenvalues of the system were further stabilized. In order to improve further the damping of electromechanical oscillation modes a supplementary controller could be designed using the STATCOM.

REFERENCES

Aweya, J., & Al Sindi, N. (2013). Role of Time Synchronization in Power System Automation and Smart Grids. *International Conference on Industrial Technology (ICIT)* (pp. 1392-1397). IEEE Press.

Bose, A. (2010a). New smart grid applications for power system operations. *IEEE power and energy society*.

Bose, A. (2010b). Smart transmission grid applications and their supporting infrastructure. *1*, pp. 11-19. IEEE.

Brunner, C., & Antonova, G. (2011). Smarter time sync: Applying the IEEE PC37.238 standard to

- power system applications in Protective Relay Engineers. *64th Annual Conference* (pp. 91-102). IEEE Press.
- Carta, A., Locci, N., Muscas, C., & Sulis, S. (2008). A Flexible GPS-Based System for Synchronized Phasor Measurement in Electric Distribution Networks. *Instrumentation and Measurement, IEEE Transactions*, 57(11), 2450-2456.
- Chakraborty, A., Chow, J. H., & Salazar, A. (2011). A measurement-based framework for dynamic equivalencing of large power systems using wide-area phasor measurements. *IEEE Trans Smart Grid* 2(1), 68-81.
- De La Ree, J., Centeno, V., Thorp, J. S., & Phadke, A. G. (2010). Synchronized phasor measurement applications in power systems. *IEEE Trans Smart Grid*, 1(1), 20-27.
- Ghosh, S., & Senroy, N. (2012). The localness of electromechanical oscillations in power systems. *International Journal of Electrical Power and Energy Systems*, 42(1), 306-313. <http://doi.org/10.1016/j.ijepes.2012.04.004>
- Graham, R. (2000). *Power System Oscillation*. Norwell, Massachusetts.: Kluwer Academic Publishers.
- James G. A., Nwohu, N. M., Tola, O. J. & Ohize, O. H. (2012). International Journal of Engineering and Technology Performance Evaluation of PSS and STATCOM on Oscillation Damping of a North-Central Power Network of Nigeria Grid System. *International Journal of Engineering and Technology*, 2(2), 209-219.
- Milano F., (2007). Documentation for power system analysis toolbox (PSAT), version 2.0.0 b; March 8, 2007.
- Mithulananthan, N., Canizares, C. A., Reeve, J., & Rogers, G. J. (2002). Comparison of PSS, SVC and STATCOM Controllers for Damping Power System. *IEEE Trans. Power Systems*, 1-8.
- Magaji, N., Mustafa, M. W., & Dan-Isa, A. (2012). Optimal location and signal selection of TCSC device for damping oscillation. *International Review of Automatic Control*, 5(2), 139-147. <http://doi.org/10.1016/j.ijepes.2011.01.020>
- Ray, W., Venayagamoorthy, G. K., Balarko, C., & Majumder, R. (2008). Comparison of Adaptive CriticBased and Classical Wide-Area Controllers for Power Systems. *IEEE Transactions On Systems, Man, And Cybernetics —Part B: Cybernetics*, 38, 1002-1007.
- Reddy, I. P., Ram, B. V. S., Pradesh, A., & Pradesh, A. (2010). Statcom With Flc for Damping of Oscillations, 2(2), 2-7.
- Robak, S., Januszewski, M., & Rasolomampionona, D. D. (2003). Power system stability enhancement using PSS and UPFC Lyapunov-based controllers: A comparative study. 2003 IEEE Bologna PowerTech - Conference Proceedings, 3, 506-511. <http://doi.org/10.1109/PTC.2003.1304440>
- Safari, A., Soulat, B., & Ajami, A. (2013). Modeling and unified tuning of distributed power flow controller for damping of power system oscillations. *Ain Shams Engineering Journal*, 4(4), 775-782. <http://doi.org/10.1016/j.asej.2013.02.003>
- Snyder, A. F. (1997). Inter-Area Oscillation Damping with Power System Stabilizers and Synchronized Phasor Measurements Inter-Area Oscillation Damping with Power System Stabilizers and Synchronized Phasor Measurements. *Electrical Engineering*, 1-5.
- Swain, S. C., Panda, S., & Mahapatra, S. (2015). A multi-criteria optimization technique for SSSC based power oscillation damping controller design. *Ain Shams Engineering Journal*, 7(2), 553-565. <http://doi.org/10.1016/j.asej.2015.05.017>
- Wang, X.-F., Song, Y., & Irving, M. (2008). *Modern Power Systems Analysis*. New York: Springer Science Business Media, LLC. Damping of Power System Oscillations by using coordinated tuning of POD and PSS with STATCOM. (2009). *Engineering and Technology*, 1066-1071.
- Weiss, M., Abu-Jaradeh, B. N., Chakraborty, A., Jamehbozorg, A., Habibi-Ashrafi, F., & Salazar, A. (2016). A wide-area SVC controller design for inter-area oscillation damping in WECC based on a structured dynamic equivalent model. *Electric Power Systems Research*, 133, 1-11. <http://doi.org/10.1016/j.epsr.2015.11.009>